

# MODEL "TSB"

## Trough Bed Belt Conveyor



- Conveys boxes, bags, cases, loose parts
- Built-in guard rails allow overhead conveying

### STANDARD SPECIFICATIONS

**Belt** - 8", 12", 18", 20", 24" and 30" Black PVC 120 belt.

**Bed** - 12 gauge painted formed steel with 2½" high vertical sides bolted to top of bed. Standard sections are 5 and 10 feet long bolted together with floor supports and splice plates.

**Tail Pulley** - 4" diameter crowned with 1⅜" diameter shaft.

**Drive Pulley** - 4" diameter and 8" diameter crowned and fully lagged. 4" diameter pulley with 1⅜" diameter shaft, 8" diameter pulley with 1⅞" diameter shaft.

**Snub-Roller** - 2" diameter for 4" diameter pulley, 2½" diameter for 8" diameter pulley.

**Return Idler** - 1.9" diameter adjustable, on 10'0" centers.

**Floor Supports** - Adjustable 28½" to 42½" from floor to top of belt. One support supplied at each end of conveyor and at each bed joint.

**Take-Up** - 6" long screws located at tail pulley to provide belt tension.

**Bearings** - Sealed-prelubricated with cast iron housings.

**Speed Reducer** - C-Face mounted heavy duty worm gear reducer.

**Motor** - ½ HP 230/460-3-60 TE motor.

**Belt Speed** - 60 FPM constant.

**Capacity** - Maximum load per lineal foot of conveyor - 75 pounds. Not to exceed Load Capacity Chart.

### OPTIONAL EQUIPMENT

**Belt** - Nitrile (white or black), with smooth top cover, Black PVC rough top, Brown Nitrile rough top. Special belts on application.

**Bed** - Higher than 2½" vertical sides, 4", 6", 9", to 12" max.

**Floor Supports** - Lower or higher than standard. Castored supports with 4" diameter or 6" diameter rigid or swivel casters.

**Ceiling Hangers** - ½" diameter threaded rods 8 feet long with locking nuts and mounting hardware. Other lengths are available.

**Gravity Conveyor Brackets** - Adjustable bracket, with 1⅜" diameter pop-out roller, for attaching wheel or roller conveyor.

**Nose-Over** - Adjustable single or double nose-over provides smooth transfer from incline to horizontal. See drawing on page 96 for details.

**Center Drive** - Mounted below conveyor or bed section. Can be placed most anywhere in conveyor length.

**Side Mounted Drive** - End drive mounted to side of conveyor section. Specify side. Minimum 6" elevation with 4" drive pulley, minimum 9" elevation with 8" drive pulley.

**Overhead Drive** - End drive mounted above conveyor. Specify clearance required.

**Auxiliary Take-Up** - Mounted below conveyor bed section. Can be placed most anywhere in conveyor length.

**Motor** - Single phase, energy efficient, explosion proof, etc. Other HP available.

**Belt Speed** - Constant and variable belt speeds available.

**Electrical Controls** - Magnetic starters and push button stations; Manual motor starters with overload protection, others.

**Hugging Strip** - Steel bars each side bolt to guard rail to prevent material from getting under belt. Must be used with a solid guard rail.

**Troughing Attachment** - Steel bars each side under belt form trough for handling loose material.

# MODEL "TSB"

Bed Length	Overall Length	Diameter Drive Pulley	Belt Width						
			8"	12"	18"	20"	24"	30"	
			Overall Width	12"	16"	22"	24"	28"	34"
Bed Width	9"	13"	19"	21"	25"	31"			
5'	5'10"	4"	Weight (lbs.)	270	290	335	360	380	410
10'	10'10"	4"		320	350	415	430	450	480
15'	15'10"	4"		390	425	520	535	570	605
20'	20'10"	4"		445	490	558	580	625	695
25'	25'10"	4"		520	570	650	680	735	820
30'	30'10"	4"		570	630	730	755	820	920
35'	35'10"	4"		621	700	810	850	920	1030
40'	40'10"	4"		695	780	890	935	1020	1140
45'	45'10"	4"		750	835	980	1020	1120	1250
50'	50'10"	4"		825	920	1070	1120	1220	1370
55'	56'2"	8"	Weight (lbs.)	880	995	1160	1215	1320	1480
60'	61'2"	8"		950	1070	1248	1303	1420	1590
65'	66'2"	8"		1000	1130	1325	1390	1520	1705
70'	71'2"	8"		1080	1220	1420	1490	1620	1825
75'	76'2"	8"		1130	1280	1504	1575	1720	1935
80'	81'2"	8"		1205	1360	1590	1665	1818	2048
85'	86'2"	8"		1255	1420	1670	1752	1920	2155
90'	91'2"	8"		1330	1500	1755	1840	2035	2325
95'	96'2"	8"		1380	1560	1835	1925	2135	2433
100'	101'2"	8"		1460	1640	1920	2015	2204	2485

## Load Capacity Chart

60 FPM	
HP	TOTAL LOAD
1/2	435 lbs.
3/4	650 lbs.
1	810 lbs.

NOTE: 1 HP Max. for this model

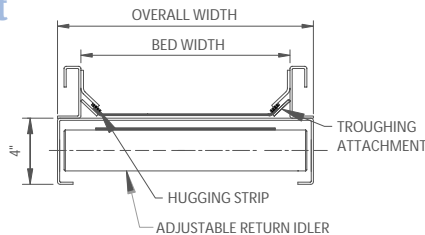

OPTIONAL HUGGING STRIP AND TROUGHING ATTACHMENT

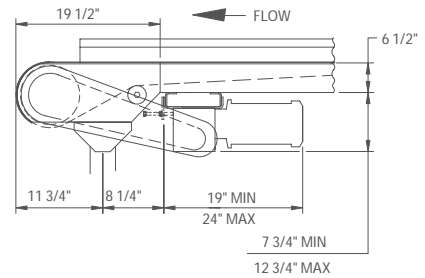

8" DRIVE PULLEY

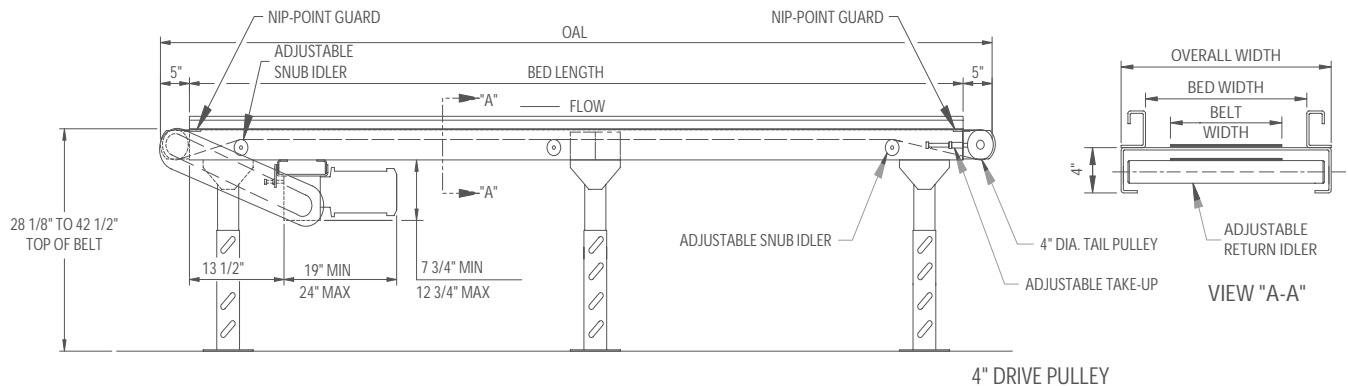

4" DRIVE PULLEY