

MODEL "138 CLR"

V-Belt Curve

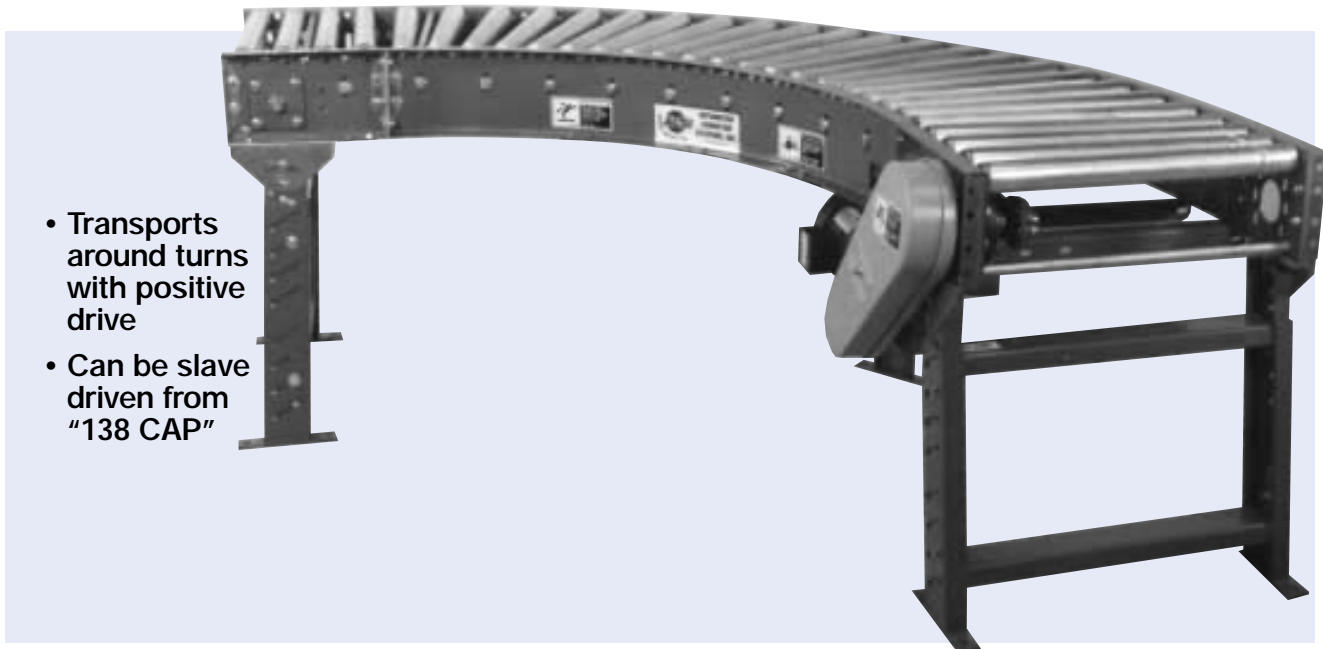

- Transports around turns with positive drive
- Can be slave driven from "138 CAP"

STANDARD SPECIFICATIONS

Driving Belt - "B" section V-belt.

Bed - Roller bed width between frames, 10", 13", 16" and 22". 5 1/2" x 1 1/2" x 12 gauge painted formed steel channel frame.

Tread Rollers - 1 3/8" diameter x 18 gauge galvanized steel tread rollers, 1 1/2" centers, 5/16" hex shaft for 13"-19" OAW. 2 1/2" to 1 11/16" tapered roller for 25" OAW conveyor, 7/16" hex shaft.

Pressure Sheaves - 3" diameter x 3/8" bore, adjustable to give required driving force.

Floor Supports - Adjustable 30" to 44" from floor to top of rollers. One support at each end, center leg on outer rail.

Tangent - 12" long, one on each end.

Take-Up - Screw take-up provided to insure proper V-belt tension. Mounted underneath conveyor.

End Drive - Mounted below bed section.

Bearings - Sealed prelubricated with cast iron housings.

Speed Reducer - C-Face mounted heavy duty worm gear reducer.

Motor - 1/2 HP 230/460-3-60 TE motor.

Conveying Speed - 60 FPM constant.

Capacity - 300 lbs. total distributed live load.

OPTIONAL EQUIPMENT

Guard Rails - Adjustable channel, continuous channel, or solid steel guard rails available.

Floor Supports - Lower or higher supports are available. Minimum elevation 15 1/2".

Ceiling Hangers - 1/2" diameter threaded rods 8 feet long with locking nuts and mounting hardware. Other lengths are available.

Side Mounted Drive - End drive mounted to side of conveyor bed section. Minimum elevation 8". Specify side.

Motor - Single phase, energy efficient, explosion proof, etc. Other HP available.

Conveying Speed - Variable and other constant speeds available.

Electrical Controls - Magnetic starters and push button stations; Manual motor starters with overload protection, others.

MODEL "138 CLR"

Overall Width	Width Between Frames	R	Number Of Rollers			Weight (Lbs.)		
			90°	45°	30°	90°	45°	30°
13"	10"	25"	42	29	24	280	265	245
16"	13"					295	275	255
19"	16"					315	285	265
25"	22"	32 1/2"	36	26	23	435	415	395

Note: 22" between rail curves are furnished with 2 1/2" to 1 1/8" diameter tapered rollers. 10", 13" and 16" between rail curves are furnished with 1 3/8" diameter straight rollers.

