

MODEL "190 CLR"

V-Belt Curve

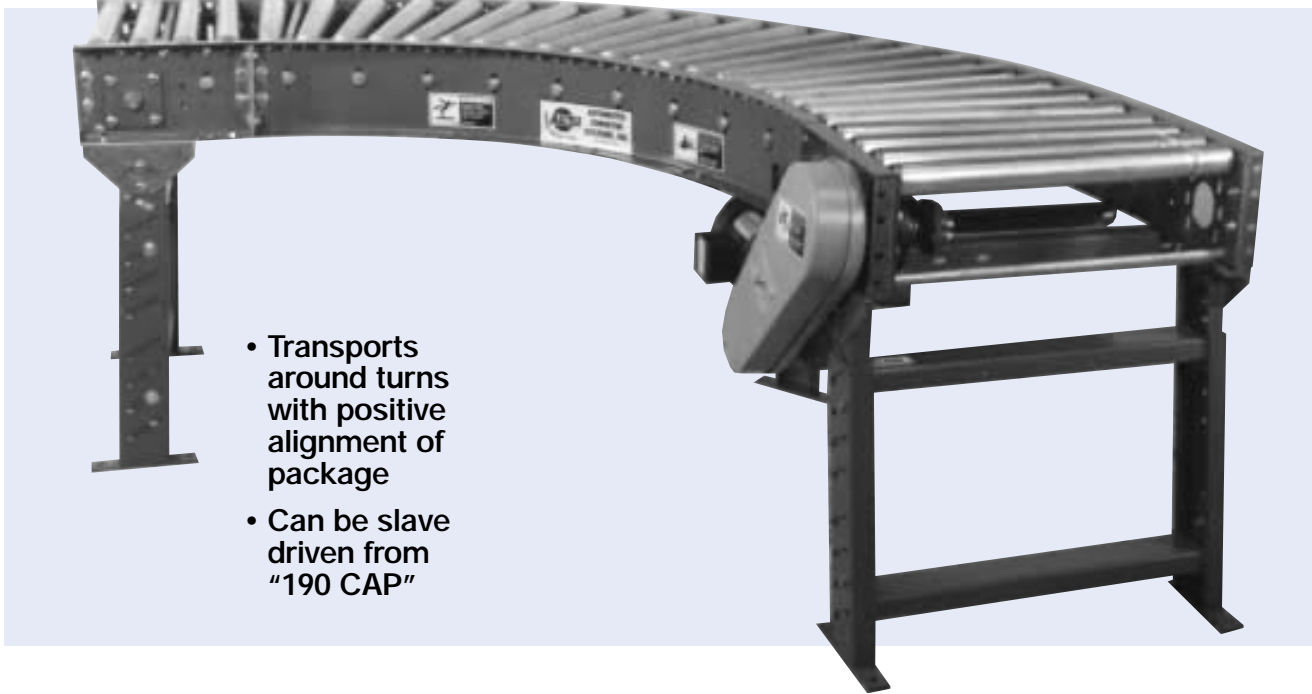

STANDARD SPECIFICATIONS

Driving Belt - "B" section V-belt.

Bed - Roller bed width between frames, 15", 21", 27", 33" and 39". 2 1/2" diameter tapered to 1 1/16" diameter x 14 gauge wall plated tread rollers. 7/16" hex shafts. Steel pressure sheaves. Mounted in 7" x 1 1/2" x 12 gauge painted steel channel frame.

Floor Supports - Adjustable 31 1/2" to 45 1/2" from floor to top of rollers. One support at each end, and center leg on outer rail.

Take-Up - Screw take-up provided to insure proper V-belt tension. Mounted underneath conveyor.

Tangent - 12" long, one on each end.

End Drive - Mounted below bed section.

Bearings - Sealed prelubricated with cast iron housings.

Speed Reducer - C-Face mounted heavy duty worm gear reducer.

Motor - 1/2 HP 230/460-3-60 TE motor.

Belt Speed - 60 FPM constant.

Capacity - 540 lbs. total distributed live load.

OPTIONAL EQUIPMENT

Guard Rails - Adjustable channel, continuous channel, or solid steel guard rails available.

Floor Supports - Lower or higher supports are available. Minimum elevation, 17" from floor to top of rollers.

Ceiling Hangers - 1/2" diameter threaded rods 8 feet long with locking nuts and mounting hardware. Other lengths are available.

Side Mounted Drive - End drive mounted to side of conveyor bed section. Minimum elevation 9 1/2". Specify side.

Motor - Single phase, energy efficient, explosion proof, etc. Other HP available.

Belt Speed - Constant and variable belt speeds available.

Electrical Controls - Magnetic starters and push button stations; Manual motor starters with overload protection, others.

Tangents - Standard tangents are 12" long, located at each end of curve. Longer tangents available. Contact Factory.

MODEL "190 CLR"

Overall Width	Width Between Frames	Radius	No. Tapered Rollers			No. Straight Rollers			Weight (lbs.)		
			90°	45°	30°	90°	45°	30°	90°	45°	30°
18"	15"	32½"	20	10	7	8	8	8	428	407	396
24"	21"		20	10	7	8	8	8	470	449	438
30"	27"		20	10	7	8	8	8	512	491	480
36"	33"	48"	30	15	10	8	8	8	540	519	508
42"	39"		30	15	10	8	8	8	568	547	526

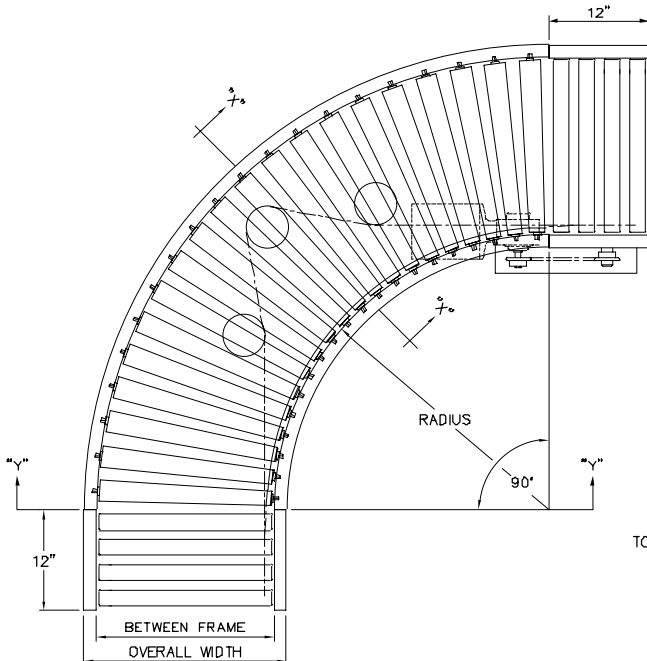
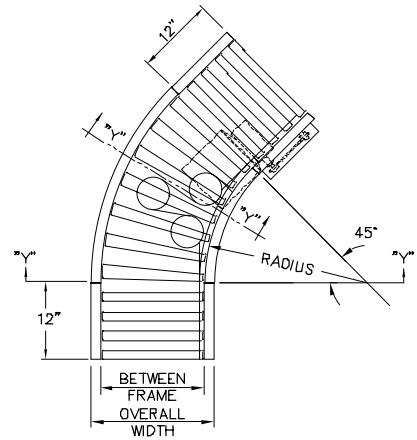
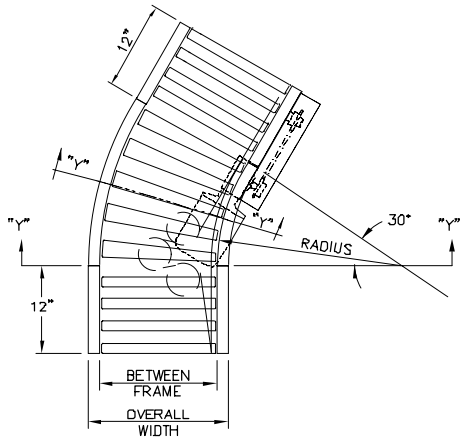

FLOW ←

